

gabriel ash

The Babygrand Coldframe – Specification

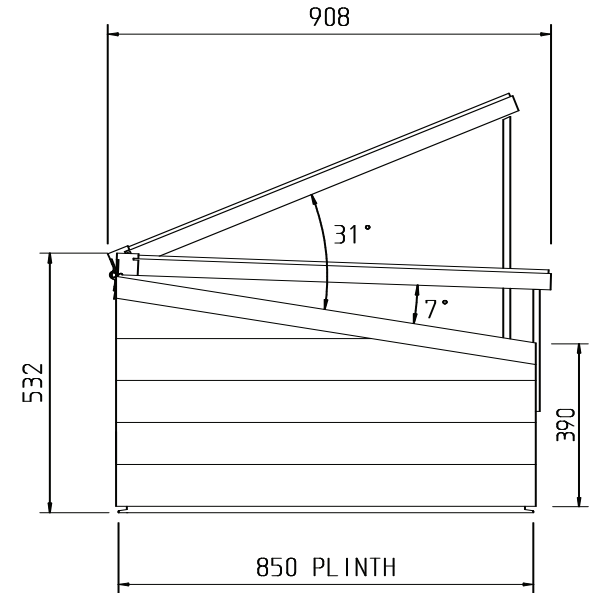

Approximate measurement: 3ft 7.5" x 2ft 9.5"

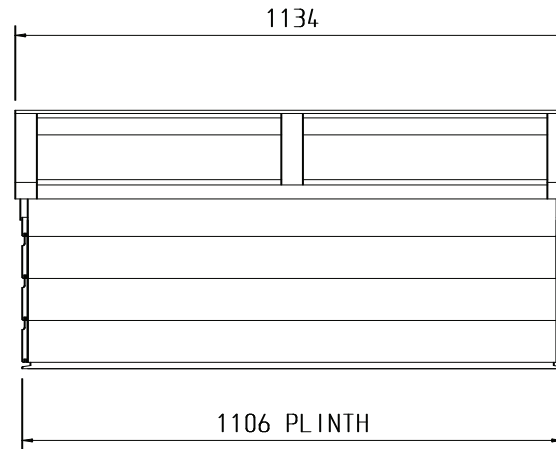

Cedar

The framework and cladding is in a top grade Western Red Cedar which is grown on the Western Sea Board of North America. It has long been used in inclement climates in the construction and garden industries due to its longevity (the timber contains natural preservatives), stability (it does not easily warp or bend being straight grained) and strength. All of our cedar is sourced from certified or sustainable forests.

Cedar absorbs moisture readily which brings the natural preservatives to the surface. There is a wide colour variation in the raw material, it mellows to a silver grey as exposed to weathering.

Glass

All our structures are glazed in Tempered Safety Glass to British Standard BS.6206 class A.

Fixings

These are a combination of solid brass and stainless steel, both being suitable for use with Western Red Cedar due to their resistance to corrosion by the timber itself and extreme weather conditions.

Aluminium

We use powder coated aluminium to provide improved weather protection.

The cedar lid is protected on the exterior by aluminium cappings with neoprene gaskets securing the glass and ensuring weatherproofing.

All our cold frames have an aluminium plinth that raises the timber off the ground protecting from rising moisture and preventing the cedar from being in direct contact with the ground.

Optional Extras

We can provide a plan for preparing a brick base for our cold frames should you prefer to replace the cedar sides with brickwork.

For further information call **01829 271 888** or order online at www.gabrielash.com